

Software Defined Receiver SDRX01B not only for radioastronomy

Jakub Kákona, kaklik@mlab.cz

March 21, 2011

Abstract

This paper describe a design of Software Defined Receiver suitable for radioastronomy purposes. The receiver which has been developed in this project replacing the old analog construction such as RadioJOVE and others.

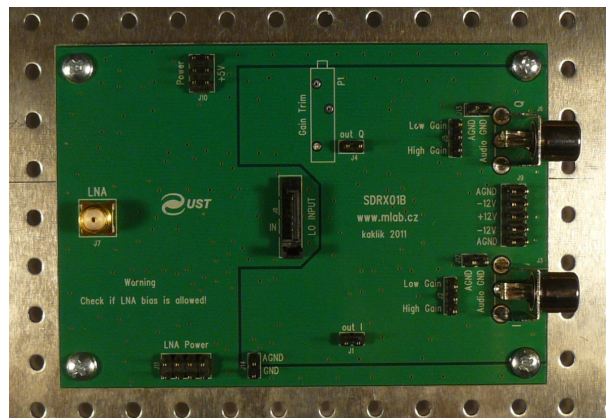

Contents

1	Technical parameters	1
2	Description of construction	2
2.1	Circuit	2
2.2	EMI suppression	10
2.3	Mechanical construction	10
2.3.1	Setting	10
3	Software tools	10

1 Technical parameters

Parameter	Value	Note
Powering voltage for analogue part	$\pm 10V$	100mA
Powering voltage for digital part	+5V	300mA
Bias of optional LNA	up to +20V	max 500mA
Frequency range	0,5 - 200 MHz	With populating by chosen parts even up 450MHz
IIP3	> 0dB	Preliminary
Gain	40-60dB	Selectable by jumper
Self noise number	< 30dB	

2 Description of construction

2.1 Circuit

Construction of the receiver is delivered from the DR2G receiver [1] which uses CMOS components completely. The main change in this construction is a local oscillator input circuit which allow to receiver work at higher frequencies, because this construction do not divide the input frequency by 4, such as original construction but only by 2. In addition there was be replaced switches in the sampling mixer by faster type and board layout was optimized for higher frequencies and better noise rejection.

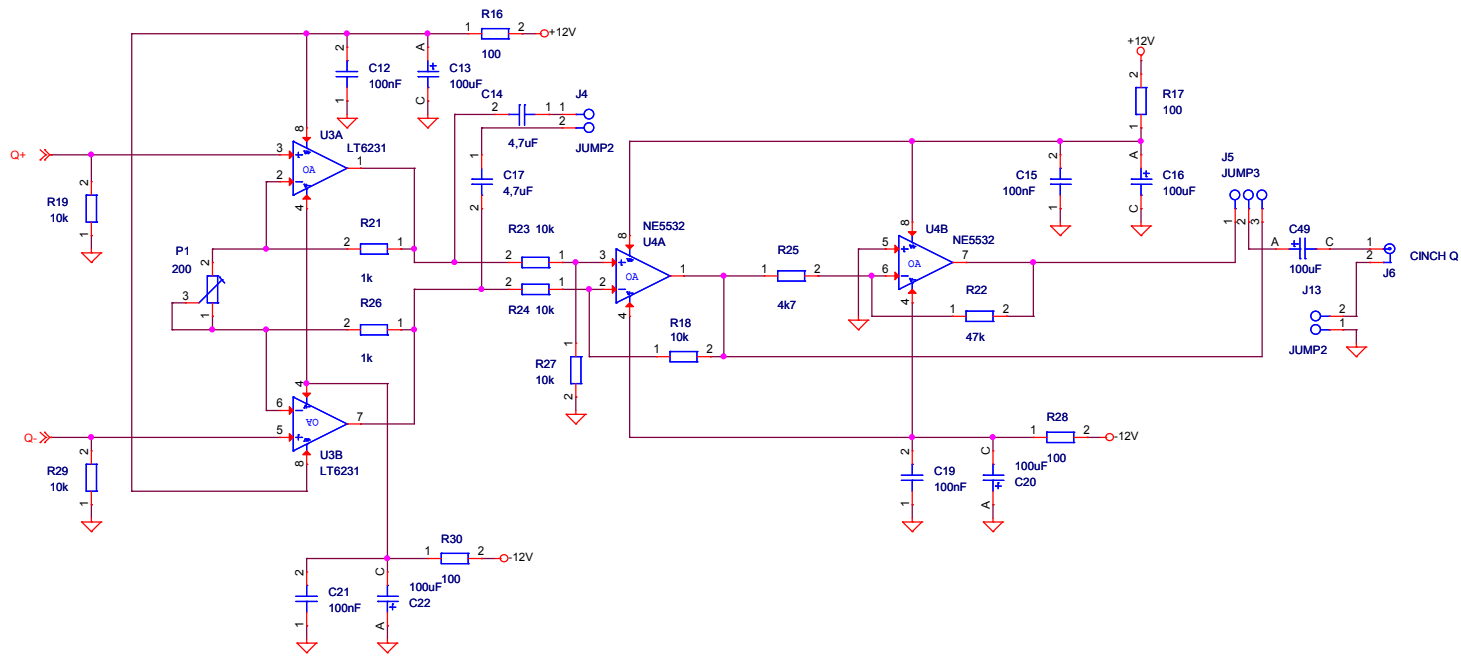
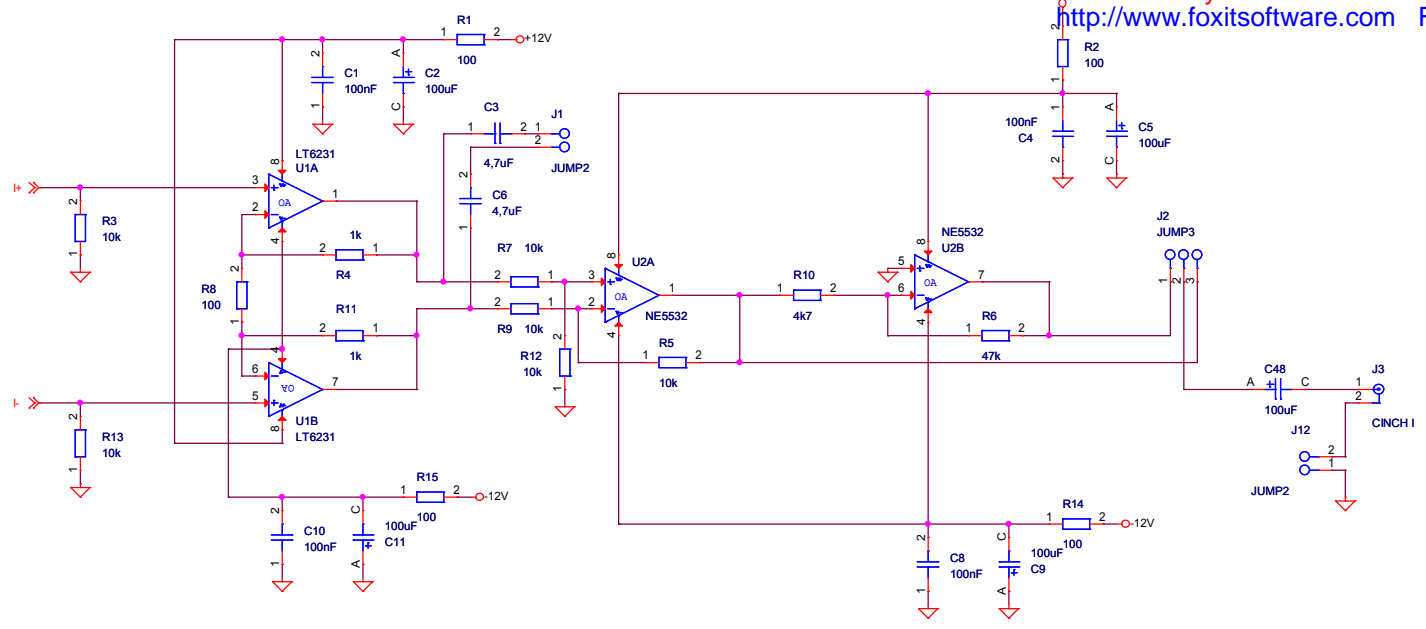

Firma	MLAB		Author	KAKLK			
Size	A3	Project Name	Software Defined Radio	Schematic Name	SDRX	Rev	B
Date:	Saturday, March 05, 2011		Sheet	1	of	4	

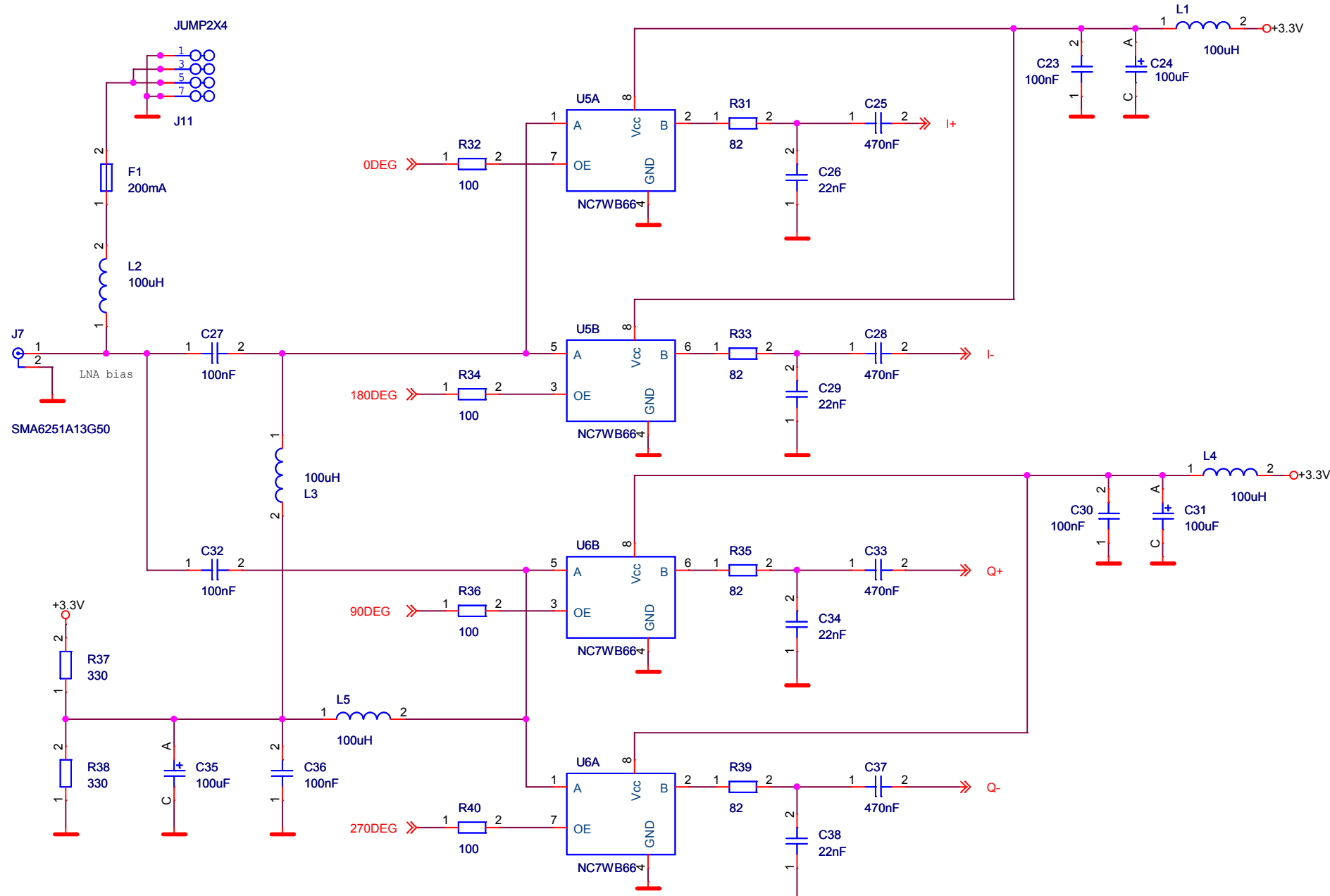

Firma		MLAB		Author KAKLIK	
Size A4	Project Name Software Defined Radio		Schematic Name SDRX		Rev B
Date:	Saturday, January 29, 2011		Sheet	2	of 4

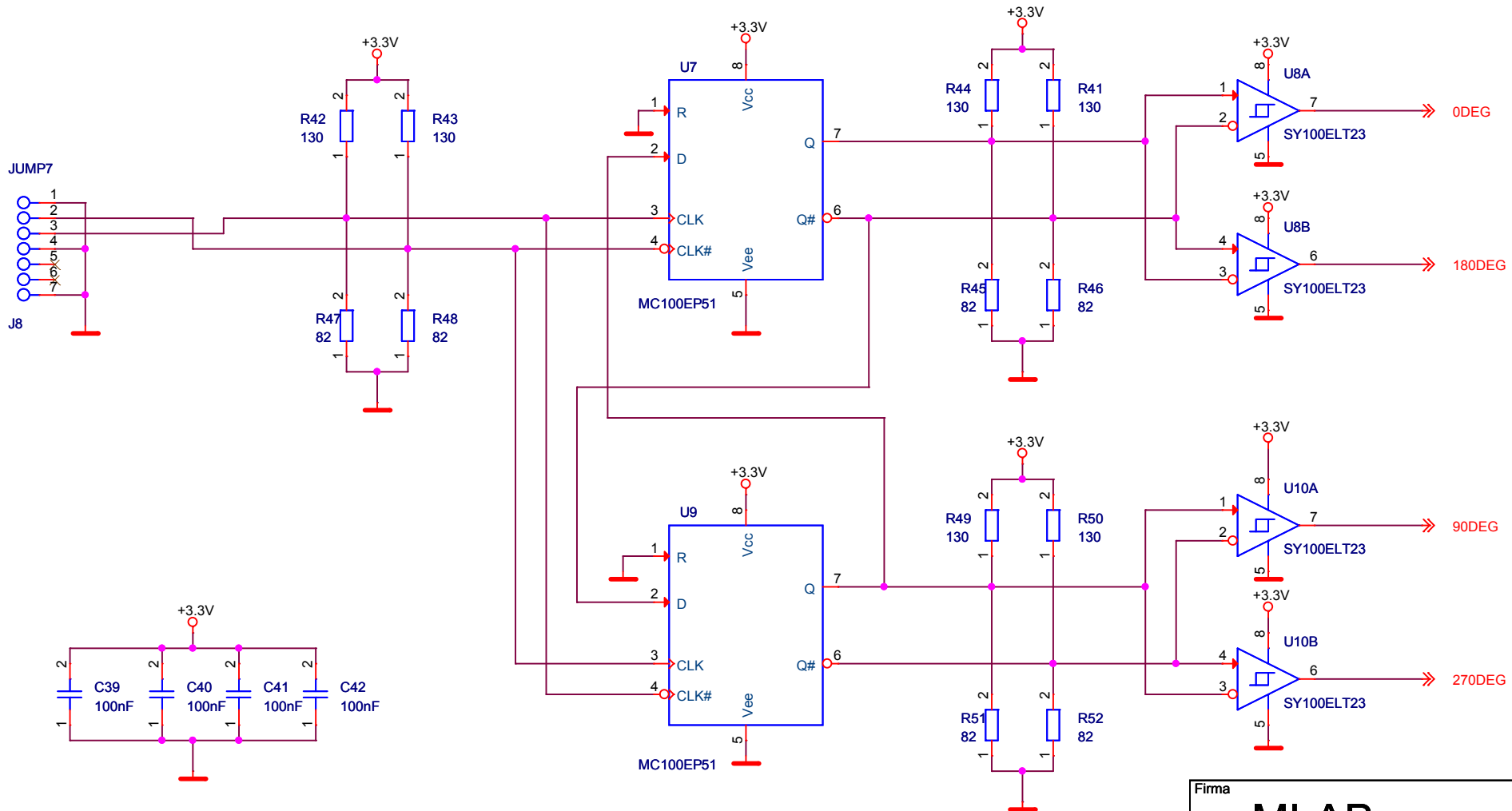

Firma			Author
MLAB			Kaklik
Size A4	Project Name Software Defined Radio	Schematic Name SDRX	Rev B
Date:	Monday, December 20, 2010	Sheet	3 of 4

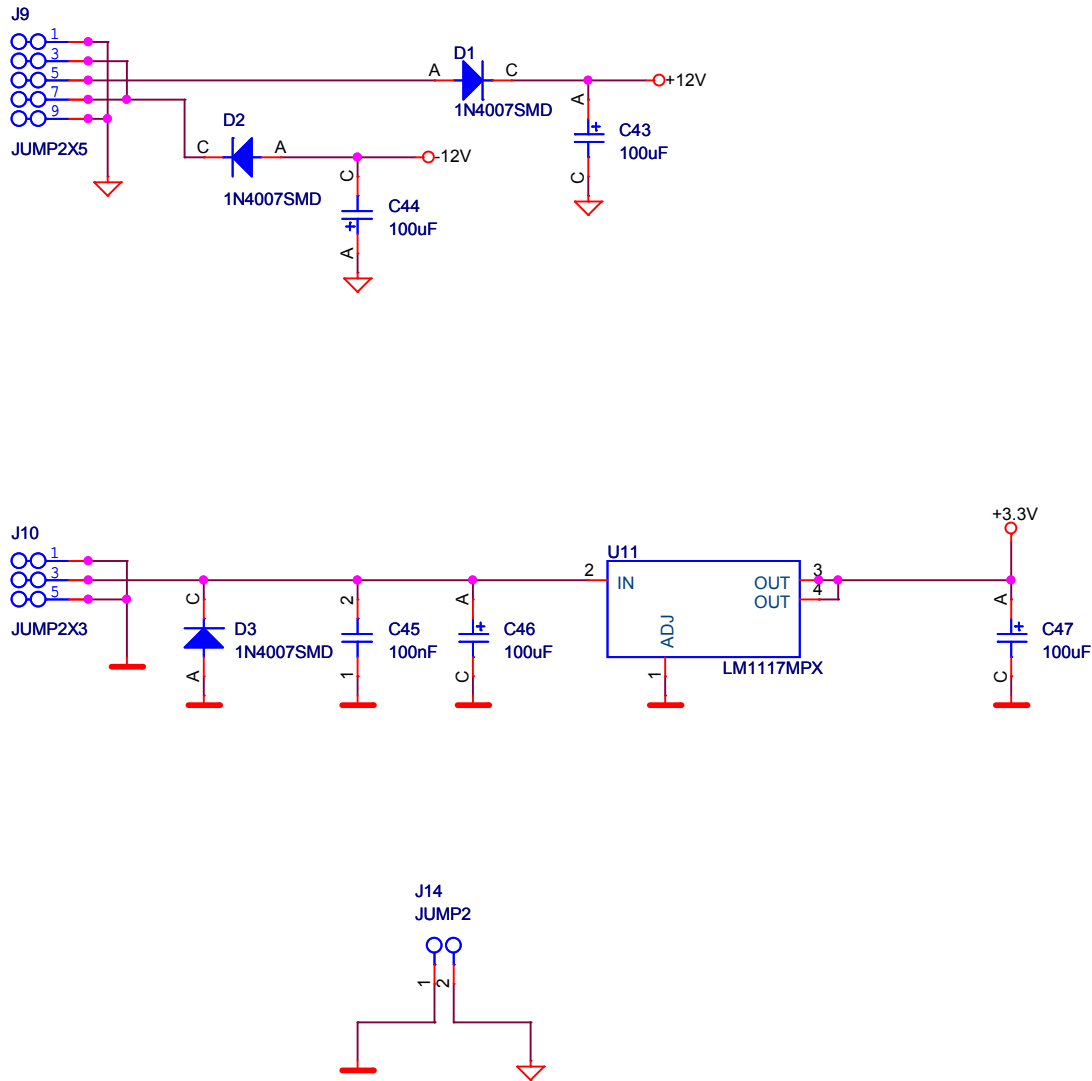

M3 FIDU
M6 FIDU_PASTE

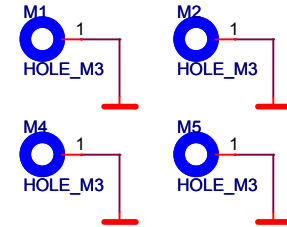

Firma		MLAB		Author KAKLIK	
Size A4	Project Name Software Defined Radio	Schematic Name SDRX		Rev B	
Date: Monday, December 20, 2010		Sheet 4 of 4			

The necessary part of the receiver is a Local Oscillator (LO), which must be connected to receiver via SATA cable. The LO may be a CLKGEN01B module populated by the 570ABB000107DG chip. SATA cable should be as short as possible to minimize ground loops.

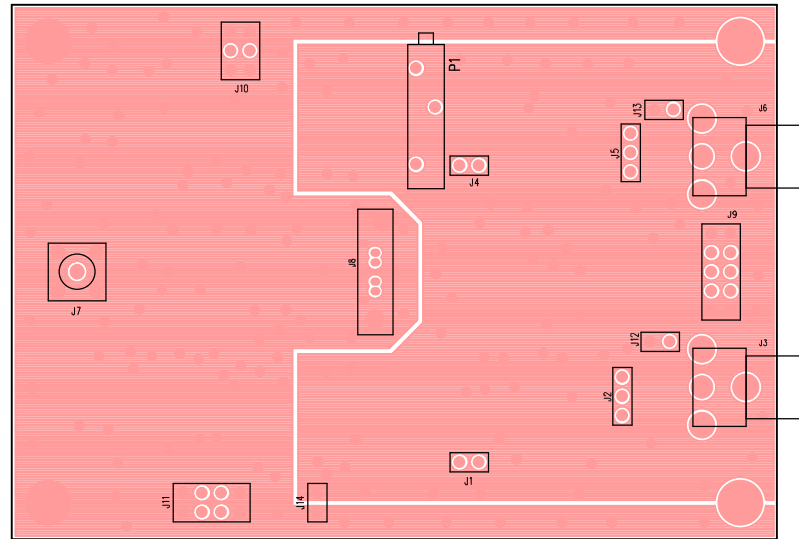

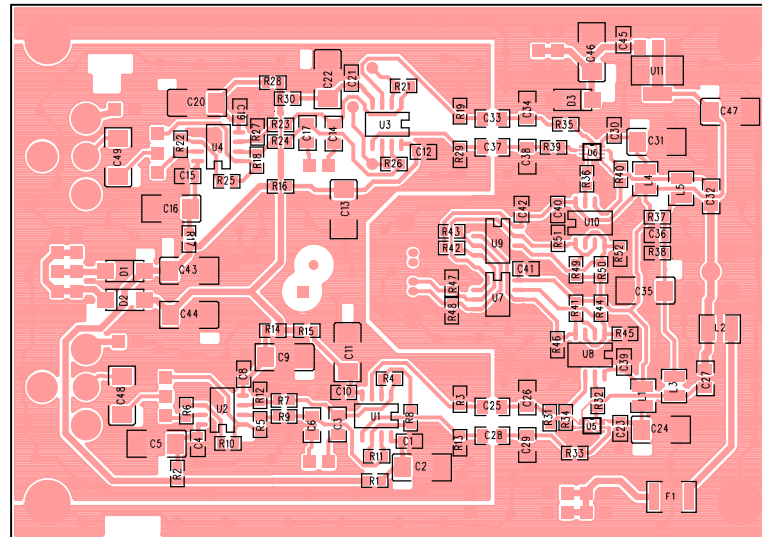

2.2 EMI suppression

For proper function of receiver is necessary to use proper low noise symmetric power supply (classical PC power supply is unacceptable). There is need for proper routing of grounding wires, which must be routed in star topology. In addition there is few jumpers on the board of receiver to allow proper selection of ground connection.

2.3 Mechanical construction

The mechanical construction of the receiver resulted (For better EMI suppression is suggested use of metal MLAB base such as ALBASE). Two layer PCB is chosen mainly because of better shielding by top cooper layer and even because better grounding. In case where long term stability is required receiver must be inserted to thermostatic box together with LO.

2.3.1 Setting

There is one easy step for proper setting of the receiver. The trimmer P1 must be tunned to value where the strength of mirror frequencies is minimized or zero. This can be achieved by tunning the receiver to some strength AM transmitter and slowly turning by P1 until the mirror of signal in frequency spectrum is minimized.

3 Software tools

The basic software tools for this receiver are all programs designed to work with sound card as I/Q input. Such as Winrad, WinradHD or Spectrum Lab. There is usually request to add a LO library for tunning Si570, but tunning the LO by separate software is acceptable too.

References

- [1] The original construction of DR2G http://yu1lm.qrpradio.com/SMT_SDR_RX_DR2G-YU1LM.pdf