

3. Key Features

- Greater than 90% Efficiency
- Adjustable Output Voltage Up to 24V
- Internal 24V Power MOSFET
- 520kHz Frequency
- Built-in Over Voltage Protection (OVP)
- Open Protection
- Programmable Soft Start Function
- Thermal Shutdown
- Under Voltage Lockout
- Over Current Protection
- SOP-8 (EP) Package

4. EV Board Schematic

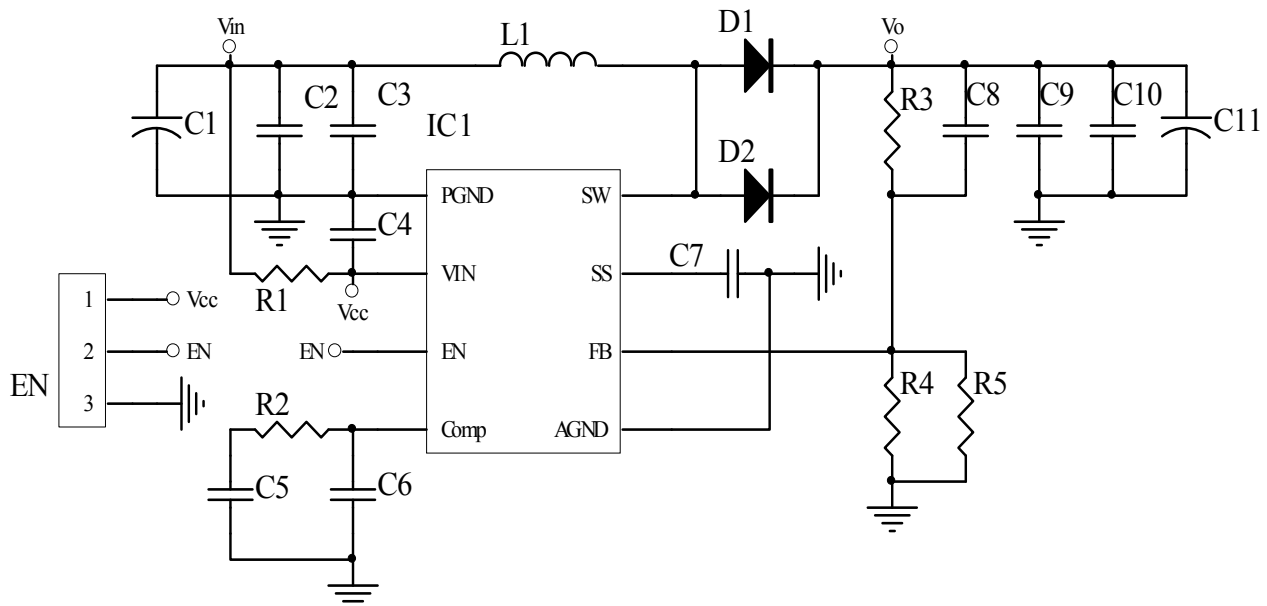

5. EVB PAM2421 TB15AA Description

PAM2421 TB15AA is an evaluation board for the PAM2421, a DC/DC boost converter. The board is targeted to be used in providing a simple and convenient evaluation environment for the PAM2421. Requires parts, power supply connectors etc. on the board, which makes it easy to be evaluated.

6. EV Board View

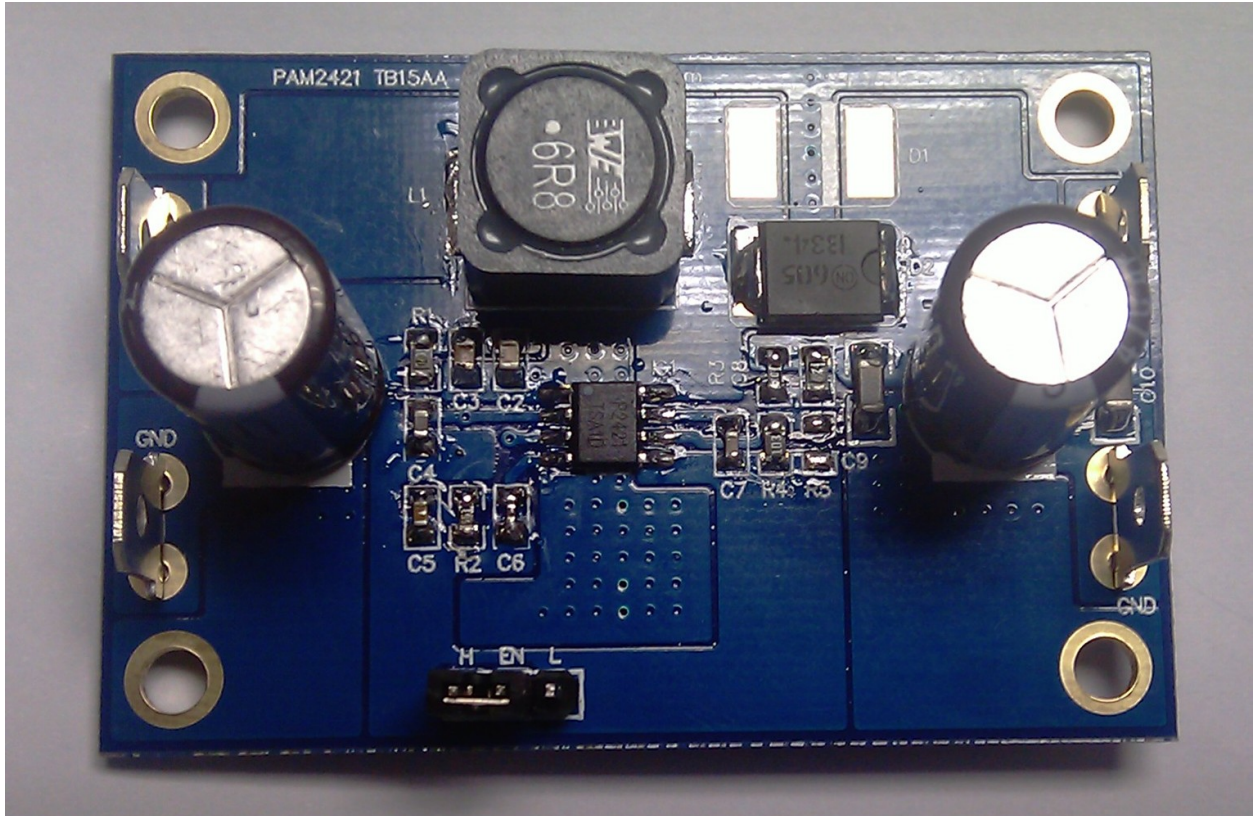

EV Board Operational Sequence:

- Connect EN to high (H side).
- Connect load to output terminal.
- Connect V_{in} and GND to power supply. $V_{in}=5V$ or Li-ion battery.

7. External Components Selection

Input & output Capacitors (C1, C2, C3, C9, C10, C11)

- (1) For lower output ripple, low ESR is required (C2, C3, C9, C10), Low leakage current needed, X5R/X7R ceramic recommend.
- (2) Provide large power, large capacitance electrolytic capacitor recommend parallel connection to the ceramic capacitor (C1, C11).

Vin filter (R1, C4)

- (1) RC filter to filtering the switching noise on IC supply, 10Ω and 1uF ceramic capacitor recommend.

Compensation net (R2, C5, C6)

- (1) R2 56kΩ, C5 2.2nF, C6 47pF recommended.

Soft start (C7)

- (1) C7 0.1uF recommended.

Schottky Diode (D1, D2)

- (1) SS34 3A/40V schottky diode recommended.
- (2) B340 3A/40V schottky diode recommended.

Feed forward capacitor (C8)

- (1) Lower the output ripple, low leakage current needed, using according to application.

Output Voltage programmer resistors (R3, R4, R5)

- (1) For programmer output voltage
- (2) For accurate output voltage, 1% tolerance is required. $V_o = 1.262 * (1 + R3/R4 // R5)$.

Inductor (L1)

- (1) Low DCR for good efficiency
- (2) Inductance saturate current must higher than the output current

8. Evaluation Board BOM List

Item	Value	Type	Rating	Description	Vender and Part No.
C1, C11	470 μ F	Ecap D10*20mm	25V		
C2, C3	10 μ F	X5R/X7R, Ceramic/0805	16V	Input coupling CAP	TAIYO YUDEN EMK212ABJ106KD-T
C9, C10	10 μ F	X5R/X7R, Ceramic/1206	25V	Output coupling CAP,	TAIYO YUDEN TMK316BJ106KL-T
C4	1.0 μ F	X5R/X7R, Ceramic/0603	25V	Vin coupling CAP	TAIYO YUDEN TMK107B7105KA-T
C5	2.2nF	X5R/X7R, Ceramic/0603	50V		TAIYO YUDEN UMK107SD222KA-T
C6	47pF	C0H, Ceramic/0603	50V		TAIYO YUDEN UMK105CH470JV-F
C7	0.1 μ F	X5R/X7R, Ceramic/0805	50V		TAIYO YUDEN UMK212B7104KG-T
L1	6.8 μ H		>3A	Inductor	WURTH 7447709006
D2	3A/40V	SS34	SMC	Schottky diode	
D1	NC		SMC		
R1	10	0805	5%		
R2	56K	0805	1%		
R3	100K	0805	1%		
R4	10K	0805	1%		
R5	NC	0805	1%		
C8	620K	0805	1%		
IC1		PAM2421	PSOP-8		
PCB		PAM2421 TB15AA			

9. PCB Layout Example

Top Layer

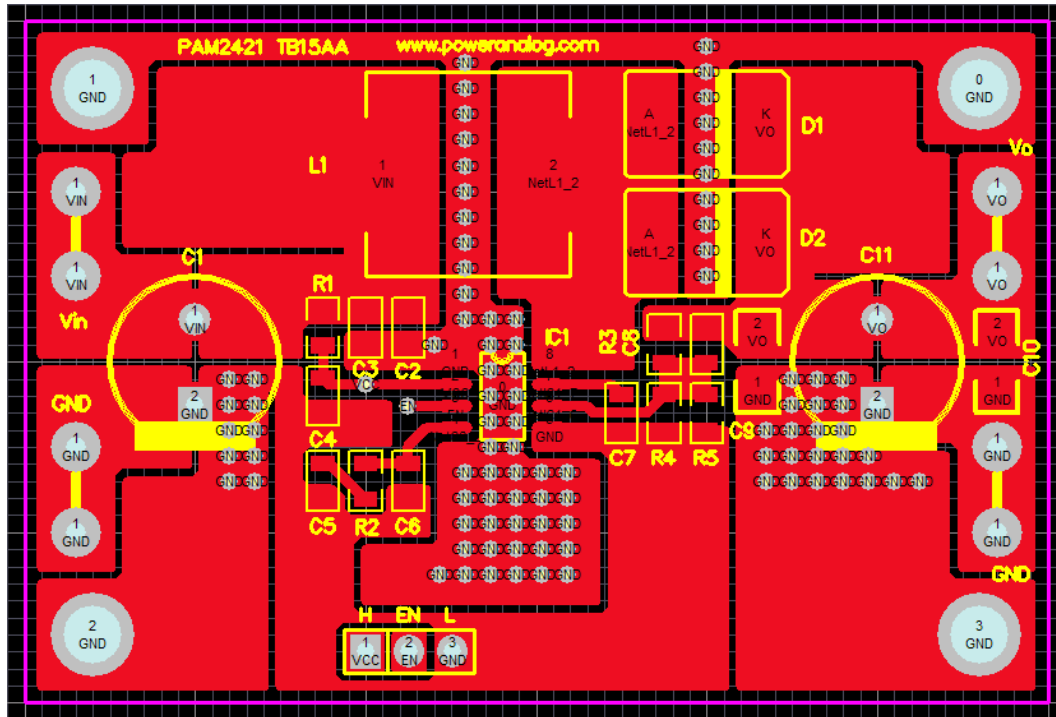

Bottom Layer

