

Laser Projector

Author:

Jakub Kákona, SPŠ SE České Bedějovice
kaklik@mlab.cz

Abstract:

Goal of this project is to design a universal laser scanning device usable for many applications such as vector graphic projection, slow time behaviour displaying or if suitable digital camera is attached we can make 3D space images or we can use it as human interface device.

Introduction

Laser projection and scanning technology is known for almost twenty years and have been used in wide range of domains. For example in military to navigation units in commerce for billing and goods identification or in geology, building industry, medicine, aeronautics and space industry or in many other applications.

At the moment some cellphone companies are thinking about using it in cellular phones to project visual data to any opaque flat plane (wall, tables and screens) it is a perspective technology which can replace large LCD panels.

Construction

Progress of this instrument started by building one of two classic galvos [1]. The first galvo had been made from standard electric motor parts. This galvo works quite well but need some feedback instrument to control his position.

In addition to making of the second axis based on this system are unsuccessful because precision of winding must be overmuch precise.

After starting failure the new scanning system was developed

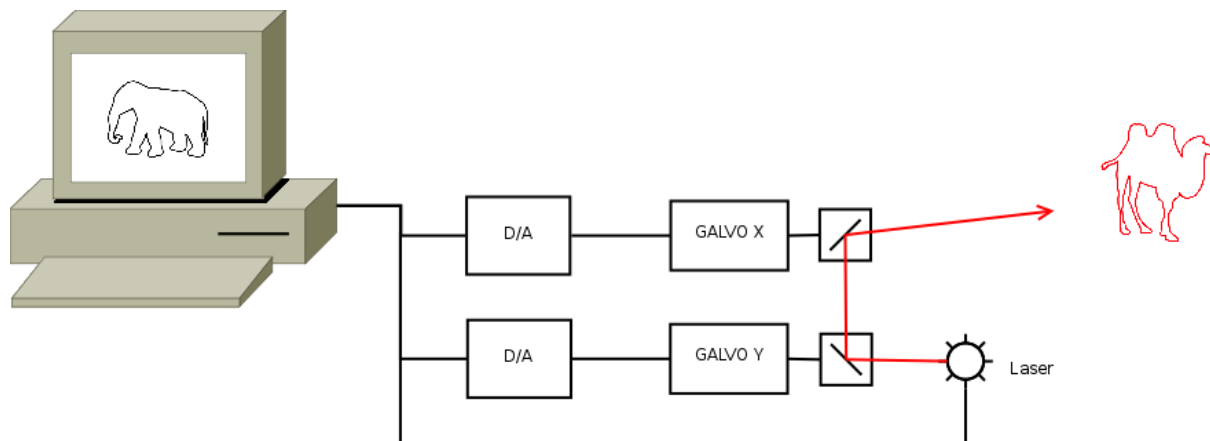

Image 1: Diagram of planned function where standard galvos are used.

Laser Unit

Laser unit is the most important part of system and is made from green laser pointer which is DPSS lasers family (also called DPSSFD, Diode Pumped Solid State Frequency-Doubled). They are much more complicated than standard red laser pointers, because laser diodes technology are not commonly available in this wavelength range.

The construction of the green laser, beginning with a high-power (typically 100-900 mW) infrared AlGaAs laser diode operating at 808 nm. The 808 nm light pumps a crystal of neodymium-doped vanadium (Nd:YVO₄) (or Nd:YAG or less common Nd:YLF), which lases deeper in the infrared at 1064 nm. The vanadium crystal is coated on the diode side with a dielectric mirror that reflects at 1064 nm and transmits at 808 nm. The crystal is mounted on a copper block, acting as a heatsink its 1064 nm output is fed into a crystal of potassium titanyl phosphate (KTP), mounted on a heatsink in the laser cavity resonator. The orientation of the crystals must be matched, as they are both anisotropic and the Nd:YVO₄ outputs polarized light. This unit acts as a frequency doubler, and halves the wavelength to the desired 532 nm. The resonant cavity is terminated by a dielectric mirror that reflects at 1064 nm and transmits at 532 nm. An infrared filter behind the mirror removes IR radiation from the output beam, and the assembly ends in a collimator lens. The output power of most green laser pointers is on the scale from 5 mW to 200mW.

Some modern green lasers uses Nd:YVO₄ is replacing Nd:YAG and Nd:YLF due to lower dependency on the exact parameters of the pump diode (therefore allowing for higher tolerances), wider absorption band, lower lasing threshold, higher slope efficiency, linear polarization of output light, and single mode output. Newer lasers use a composite Nd:YVO₄/KTP crystal instead of two discrete ones.

The laser unit is directly powered from +5V power supply via linear voltage stabilizer (LM108601A)[3] adjusted to +3V.

Scanning system

The scanning system is build from old CDrom heads. And it is controlled by PC sound card via power operational amplifier module OZPOWER01A [3]. The heads are removed from its carrier and mounted around the plastic lenses. This system allow to move the lens in two axis, This movement bring laser beam offset which can move laser point in two axis on the projection screen.

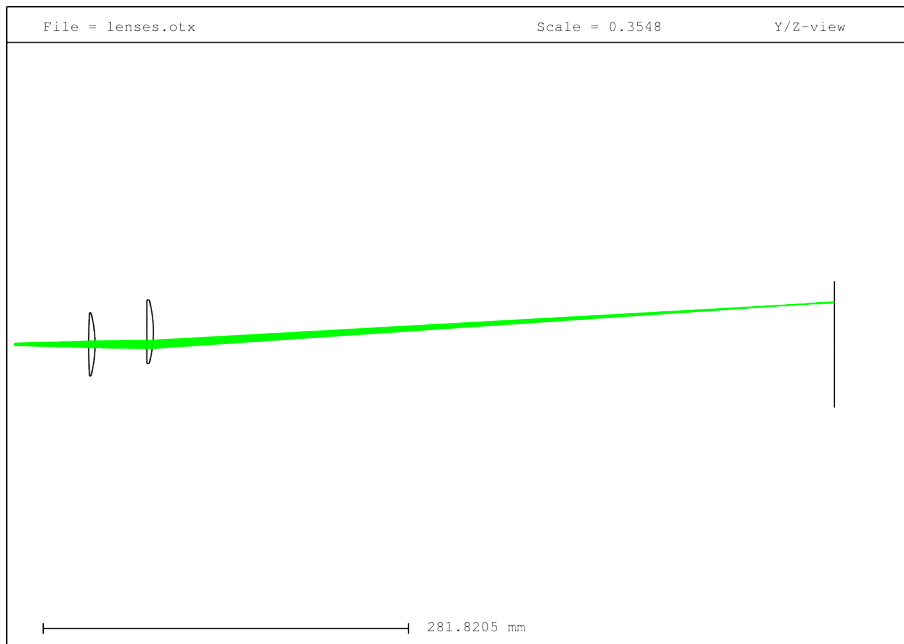

Image 2: The new scanning system principle.

This new design don't need an feed back circuit. But precise description of movement dynamics is necessary.

Some measurement was done at the mechanics system.

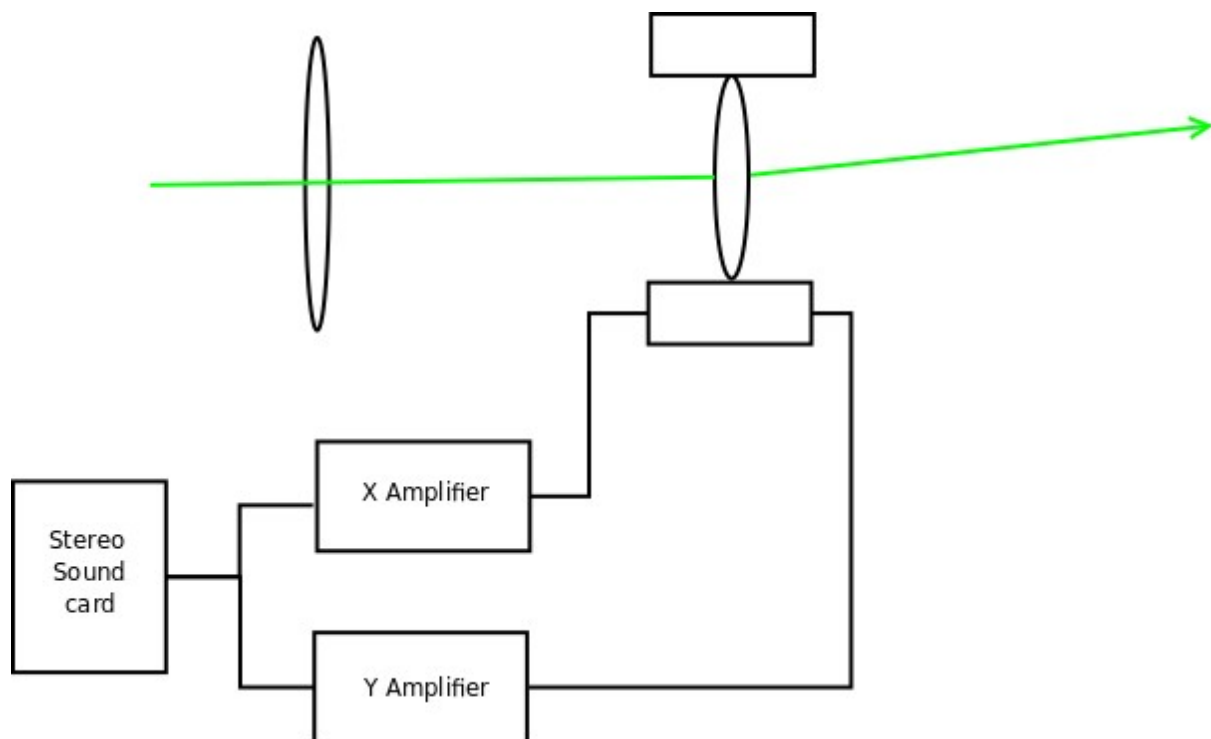
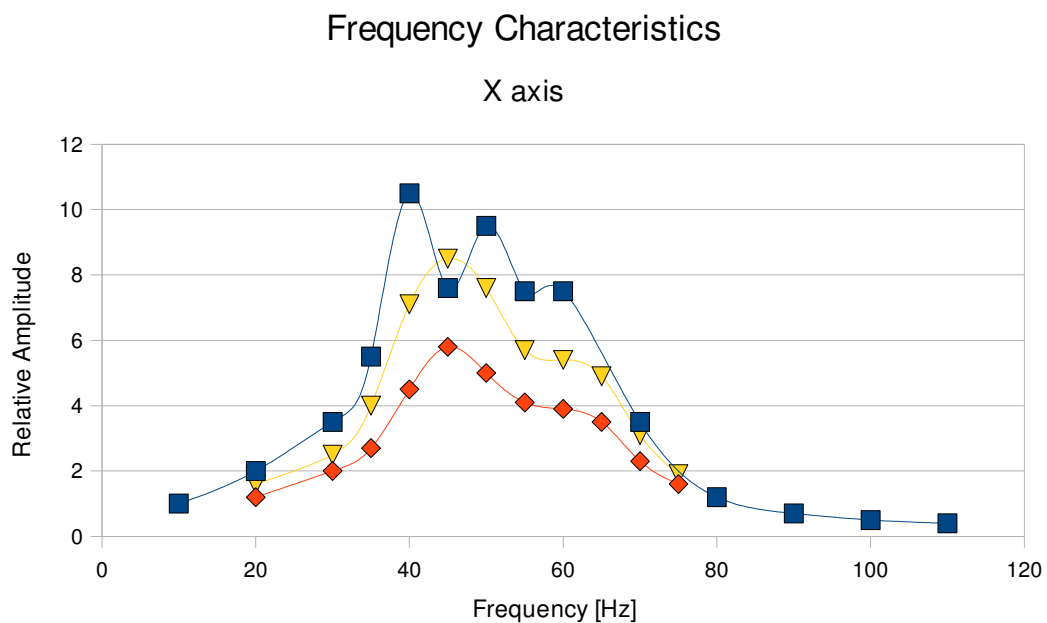

Image 3: Diagram of the used principle – optical lenses moving method

X axis			
Frequency	Amplitude 0,02	Amplitude 0,01	Amplitude 0,015
10	1		
20	2	1,2	1,6
30	3,5	2	2,5
35	5,5	2,7	4
40	10,5	4,5	7,1
45	7,6	5,8	8,5
50	9,5	5	7,6
55	7,5	4,1	5,7
60	7,5	3,9	5,4
65		3,5	4,9
70	3,5	2,3	3,1
75		1,6	1,9
80	1,2		
90	0,7		
100	0,5		
110	0,4		

Table 1: Frequency characteristics

A graphical representation of Table 1. is in the next graph.



Graph 1: Resonance Frequencies

In the graph are shown few characteristics for different input signal amplitude. The highest line represents over excited system which have more than one resonant frequency.

Y axis	
Frequency	Amplitude 0,03
10	1
20	2
30	3
35	3,7
40	5,5
45	7,8
50	8
55	4,6
60	3,5
65	2,3
70	2
75	1,4
80	1,4
90	0,8
100	0,7
110	0,5

Table 2:

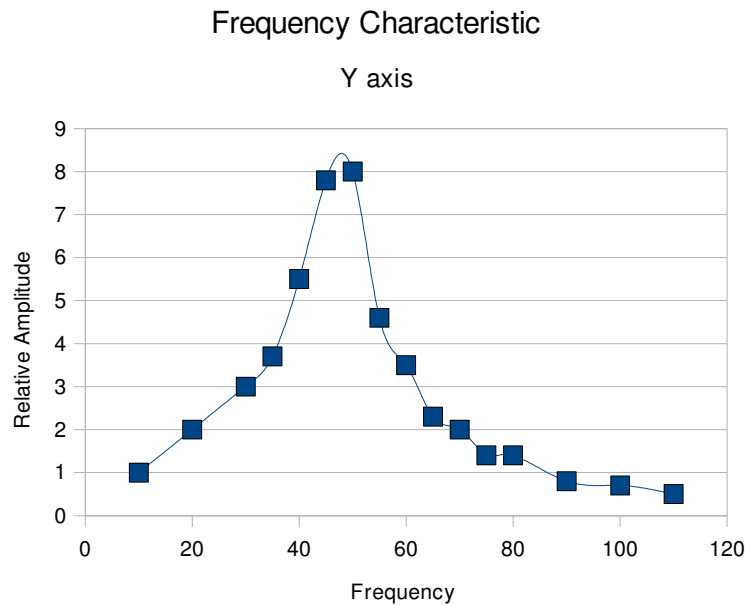

Graph 2:

We can see here resonant frequency of Y axis it is about 47Hz.

Controlling

I have tried some signal processing software Heathcliff from OpenSource GRC (Gnu Radio Companion) which is an radio software for easy programing flow control graphs. Next open source was tried Mando. Mando is designed as human inteface for projection screens and allow detecting of laser spot by web camera in purpose to create some human interface device usable on presentations.

Summary

In the project we have quite successfully design of the hardware platform. The scanning platform have pretty easy construction with is accessible for any experimenter. Next goal probably will be programing some useful software for more rigorously control the platform and which can do some image processing for digital camera usage.

Thanks

MP-Jet company for little sponsoring by neodymium magnets and some other galvo parts.

References

- [1] ELM CHAN http://elm-chan.org/works/vlp/report_e.html, 2004
- [2] wikipedia http://en.wikipedia.org/wiki/Laser_pointer
- [3] <http://www.mlab.cz/Server/GenIndex/GenIndex.php?lang=cs&path=/Modules>